

ACCELERATOR CONTROL, FUEL & EXHAUST SYSTEMS

SECTION FE

CONTENTS

PREPARATION/ACCELERATOR CONTROL SYSTEM	2	FUEL SYSTEM	3
Special Service Tool	2	Fuel Tank	3
Accelerator Control System	2	Fuel Pump and Gauge	5
Adjusting Accelerator Wire	2	EXHAUST SYSTEM	7

GI
MA
EM
LC
EC
FE
CL
MT
AT
PD
FA
RA
BR
ST
RS
BT
HA
EL
OX

Special Service Tool

Tool number Tool name	Description	
KV999G0010 Fuel tank lock ring socket		Removing and installing fuel tank lock ring
	NT057	

Accelerator Control System

CAUTION:

- When removing accelerator wire, make a mark to indicate lock nut's initial position.
- Check that throttle valve opens fully when accelerator pedal is fully depressed. Also check that it returns to idle position when pedal is released.
- Check accelerator control parts for improper contact with any adjacent parts.
- When connecting accelerator wire, be careful not to twist or scratch wire.
- Refer to "AUTOMATIC SPEED CONTROL DEVICE" in EL section for ASCD wire adjustment.
- Refer to "ON-VEHICLE SERVICE" in AT section for Kickdown switch adjustment.

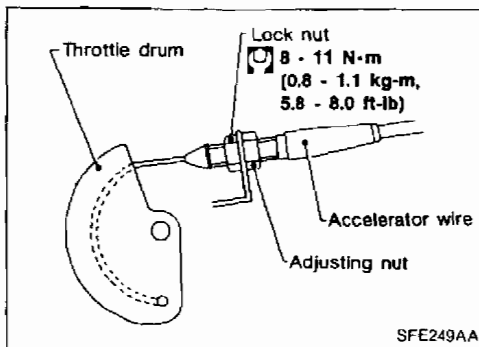
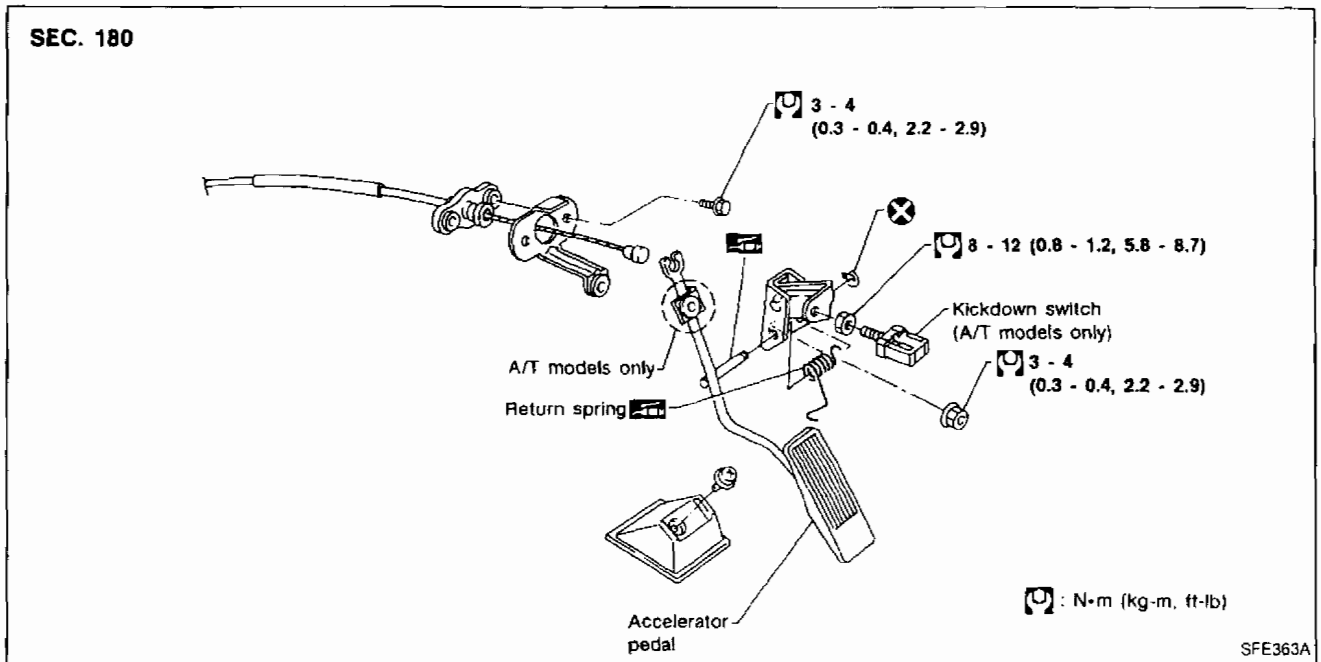

Adjusting Accelerator Wire

1. Loosen lock nut, and tighten adjusting nut until throttle drum starts to move.
2. From that position turn back adjusting nut 1.5 to 2 turns, and secure lock nut.

FUEL SYSTEM

WARNING:

- Do not smoke while servicing fuel system. Keep open flames and sparks away from work area.
- Be sure to furnish workshop with a CO₂ fire extinguisher.

CAUTION:

- Before removing fuel line parts carry out the following procedures:
 - Put drained fuel in an explosion-proof container and put the lid on securely.
 - Release fuel pressure from fuel line. Refer to "Changing Fuel Filter" in MA section.
 - Disconnect battery ground cable.
- When installing fuel check valve, be careful of its designated direction. (Refer to EC section.)
- Always replace O-ring and clamps with new ones.
- Do not kink or twist tubes when they are being installed.
- Do not tighten hose clamps excessively to avoid damaging hoses.
- After installing tubes, run engine and check for fuel leaks at connections.

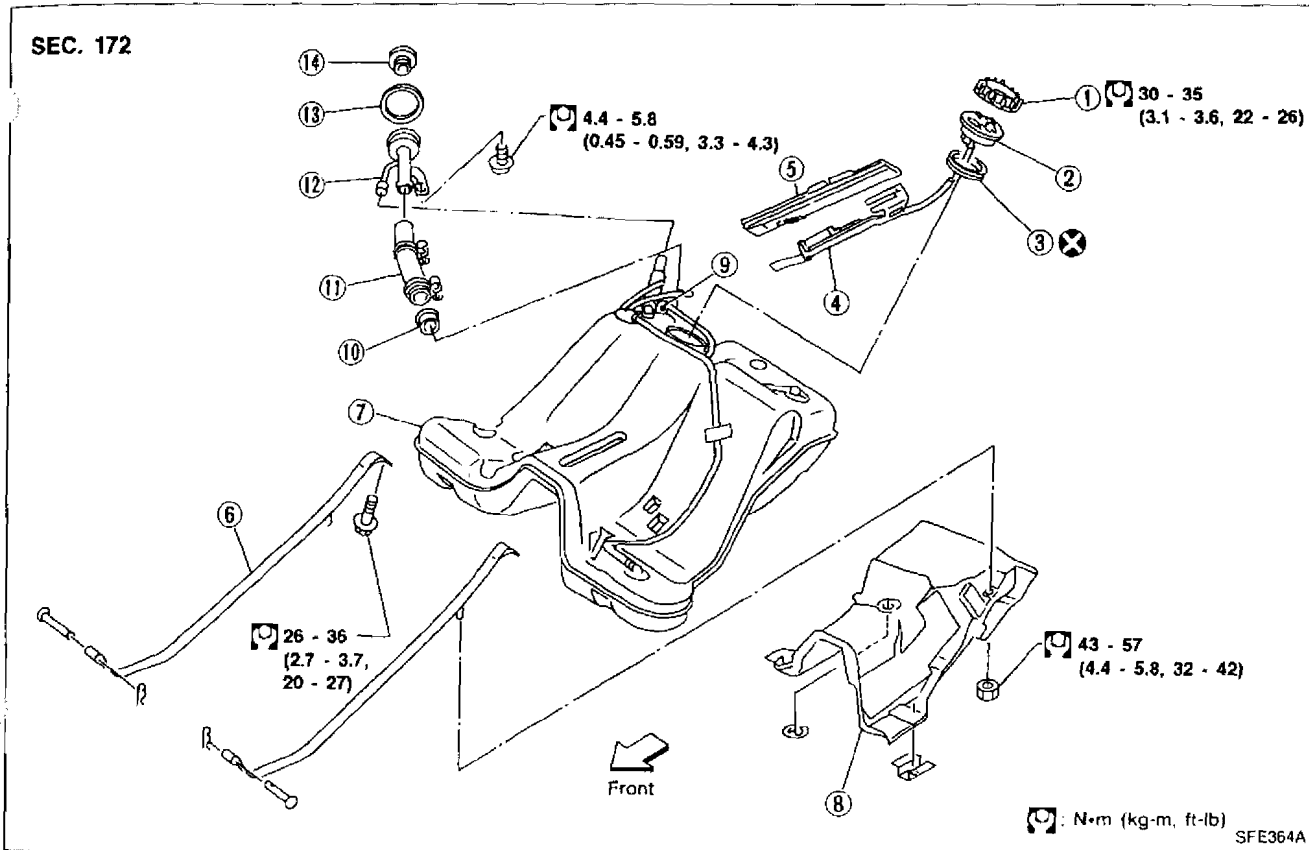

- | | | |
|----------------|-----------------------|---------------|
| ① Lock ring | ⑥ Mounting band | ⑪ Filler hose |
| ② Upper plate | ⑦ Fuel tank | ⑫ Filler tube |
| ③ Seal packing | ⑧ Fuel tank protector | ⑬ Grommet |
| ④ Fuel pump | ⑨ Fuel check valve | ⑭ Filter cap |
| ⑤ Fuel gauge | ⑩ Filler collar | |

Fuel Tank

REMOVAL

CAUTION:

- Do not disconnect any fuel line unless absolutely necessary.
- Plug hose and pipe openings to prevent entry of dust or oil.

GI
MA
EM
LC
EC
FE
CL
MT
AT
PD
FA
RA
BR
ST
RS
BT
KA
EL

BOX

FUEL SYSTEM

Fuel Tank (Cont'd)

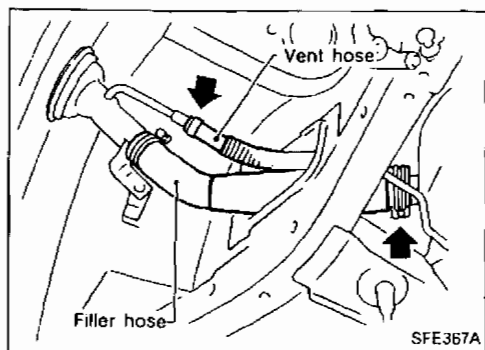
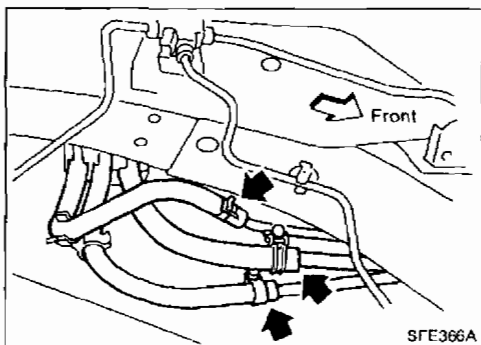
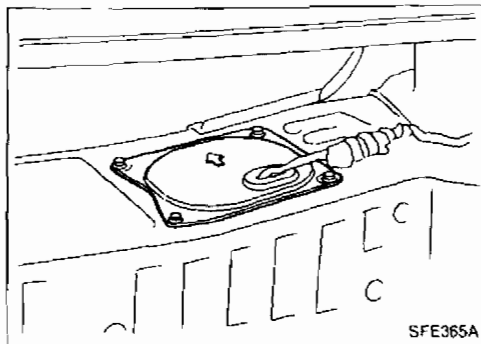

1. Release fuel pressure from fuel line.
Refer to "Changing Fuel Filter" in MA section.
2. Remove inspection hole cover located behind the rear seat.
3. Disconnect harness connectors under inspection hole cover.
4. Disconnect fuel tubes located on the lower right-hand side of fuel tank.
 - Put mating marks on tubes for correct installation.
5. Remove exhaust center tube, propeller shaft, differential carrier, rear suspension member and drive shafts (Refer to RA section).
6. Disconnect filler hose at fuel tank side and vent hose at filler tube side.
7. Remove fuel tank protector.
8. Remove fuel tank band mounting bolts while supporting fuel tank.
9. Remove fuel tank.

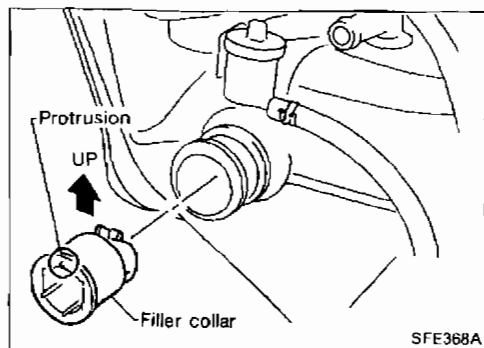

INSTALLATION

Installation procedure is the reverse order of removal.

- When installing filler collar, place the protrusion of the collar flange upward.

FUEL SYSTEM

Fuel Tank (Cont'd)

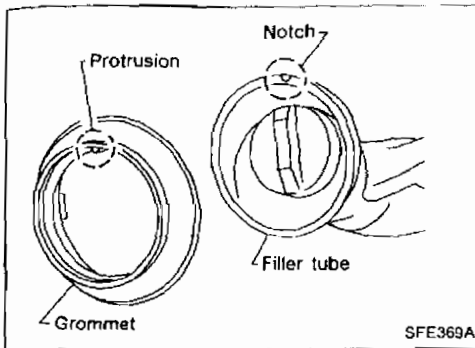

- When installing the grommet of the filler tube, align the protrusion on the grommet with the notch on the filler tube.

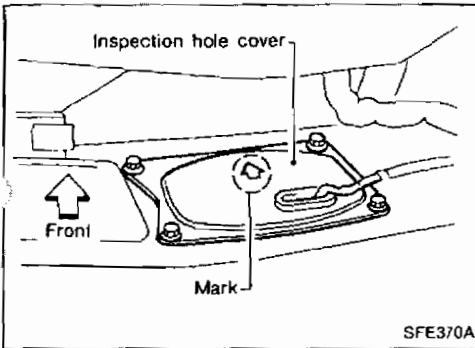

- When installing the inspection hole, put the arrow mark forward.

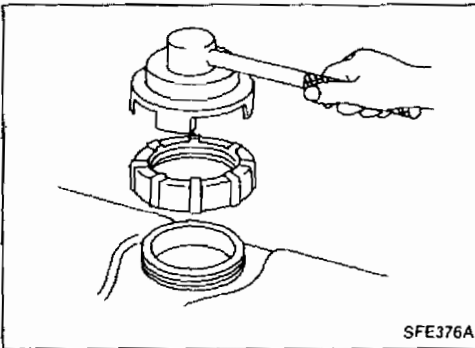

Fuel Pump and Gauge

REMOVAL

1. Release fuel pressure from fuel line.
Refer to "Changing Fuel Filter" in MA section.
2. Remove inspection hole cover located behind the rear seat.
3. Disconnect harness connectors and fuel tubes on upper plate.
- Put mating marks on tubes for correct installation.
4. Remove lock ring (Use Tool).
5. While lifting upper plate, disconnect fuel tube and harness connectors.

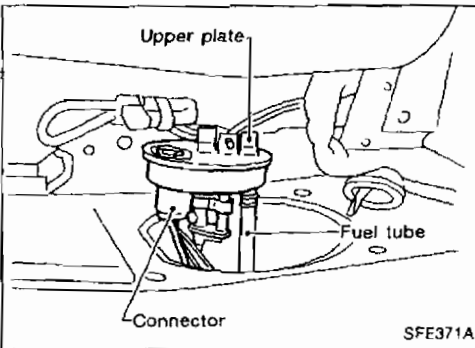

GI

MA

EM

LC

EC

FE

CL

MT

AT

PD

FA

RA

BR

ST

RS

BT

HA

EL

IDX

FUEL SYSTEM

Fuel Pump and Gauge (Cont'd)

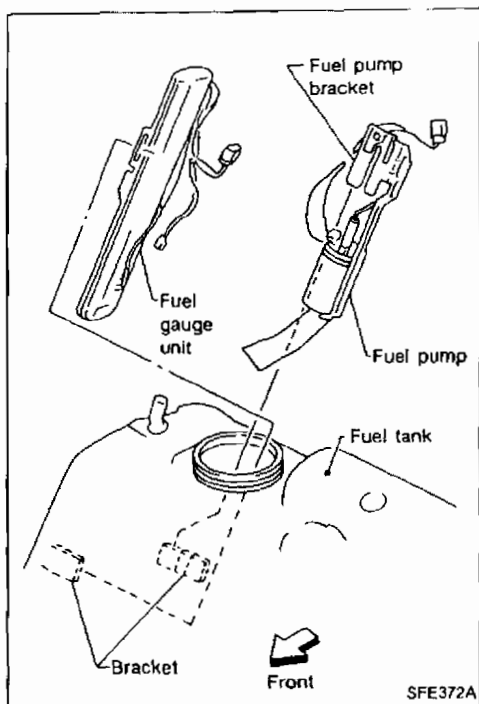

6. Remove fuel pump pulling the top end of the fuel pump bracket upward.
7. Remove fuel gauge unit.
 - a. Pull fuel gauge unit horizontally to the left.

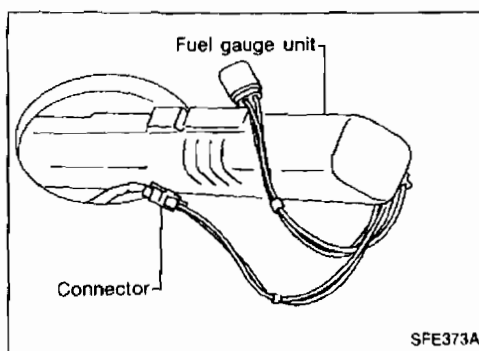

- b. Remove harness connector.
 - Carefully place the removed connector in the fuel tank so that it can be pulled out for the installation.

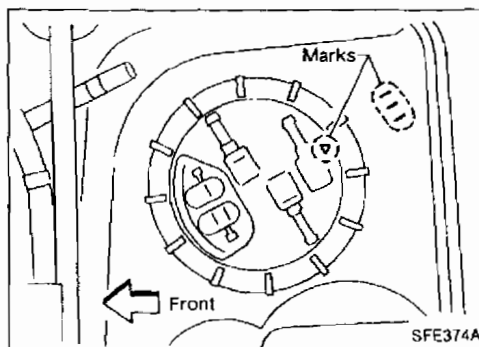

INSTALLATION

Installation procedure is the reverse order of removal.

CAUTION:

- When installing upper plate, align the mark on it with the center of marks on fuel tank.

EXHAUST SYSTEM

CAUTION:

- Always replace exhaust gaskets with new ones when reassembling.
- With engine running, check all tube connections for exhaust gas leaks, and entire system for unusual noises.
- After installation, check to ensure that mounting brackets and mounting insulator are free from undue stress. If not installed properly, excessive noise or vibration may be transmitted to the vehicle body.

GI
MA
EM
LC
EC
FE
CL
MT
AT
PD
FA
RA
BR
ST
RS
BT
HA
EL
IDX

SEC. 200

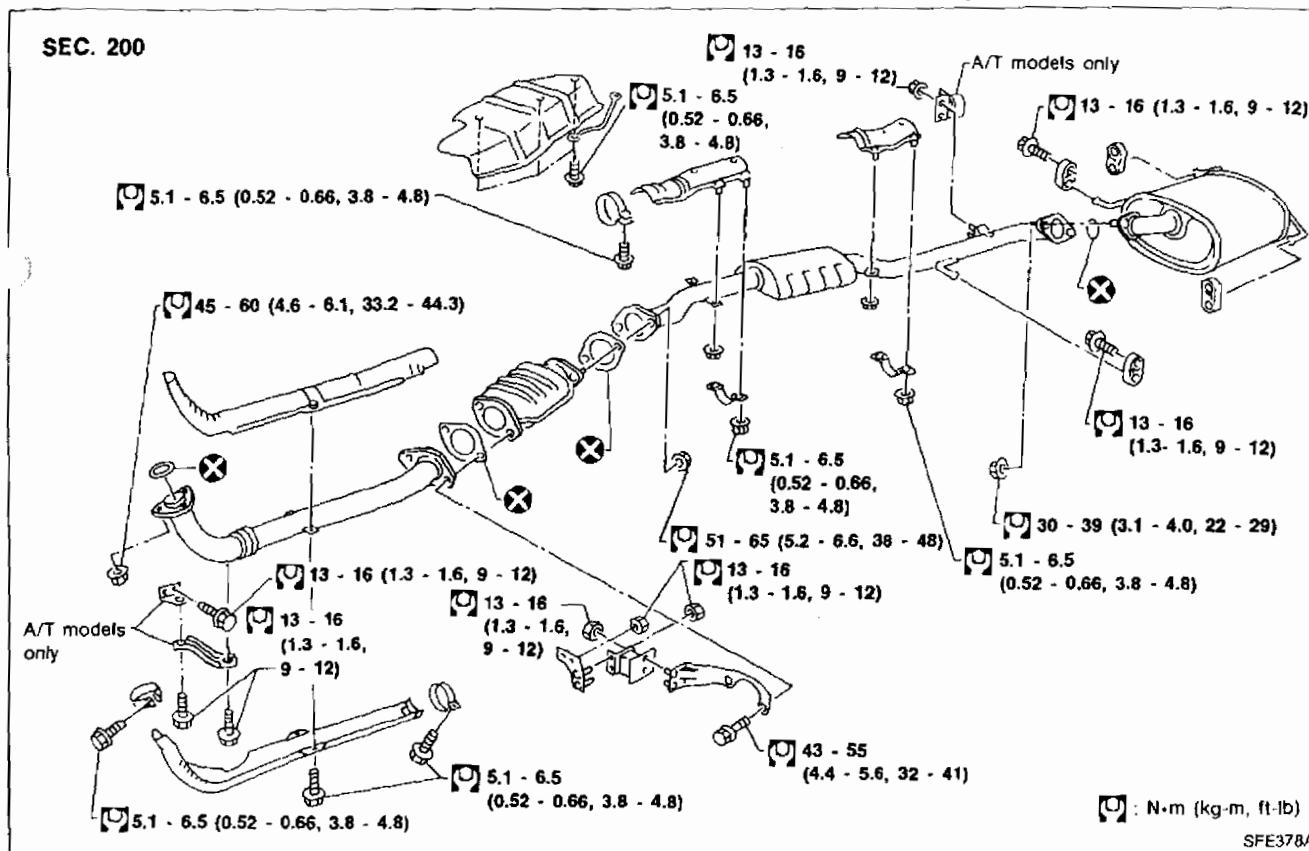

SFE378A